

# NEEDLE THRUST BEARINGS

# ROLLER THRUST BEARINGS

---



# Technical features

## Needle thrust bearings-Roller thrust bearings

The rolling elements of a thrust bearing are retained and guided in radial pockets within the cage (1). The latter is itself retained in relation to the plate (2) by means of a steel ring (3). This assembly of parts is easy to handle and install and provides a high axial load capacity whilst occupying minimal space.

The design of Nadella thrust bearings serves to reduce to a minimum the friction between the rolling elements and the cage that guides them. Given correct installation and adequate oil lubrication, the coefficient of friction will be between 0.003 and 0.004 for needle thrust bearings and between 0.004 and 0.005 for roller thrust bearings.

This result is due principally to the design of the one-piece steel cage (1) which has a special curvature that guides the rolling elements by their ends along their centre-lines.

Thus, the loads imposed on the cage by the rollers cannot create components parallel to the axis of rotation and therefore no increase in internal friction is generated, and correct operation without wear or overheating is ensured. In addition, this special curvature gives the steel cage great rigidity and being relatively thin provides maximum space for the lubricant.

### TYPES OF THRUST BEARINGS

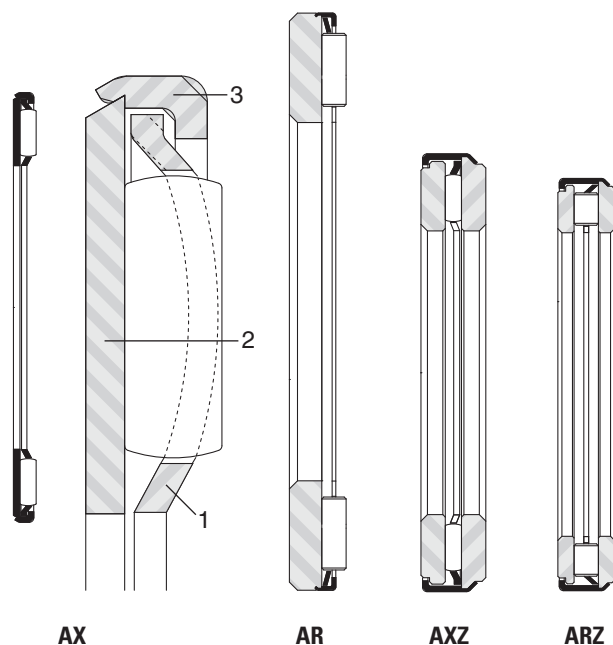

### THRUST PLATES

The plate incorporated in the thrust bearing is made from hardened bearing steel and forms one of the raceways for the rolling elements. The opposing raceway is generally provided by a separate thrust plate of similar design supplied by Nadella. When the thrust bearing is centred by the revolving part, the thrust plate must be centred by the stationary part and vice versa. If the revolving part and the stationary part are noticeably eccentric to each other, the thrust bearing with integral plate must without exception be centred by the revolving part (see mounting examples on pages 140 and 141).

The second raceway for the rolling elements may also be formed by the face of a shoulder or an inserted ring, provided these have the correct geometrical dimensions and hardness.

### THRUST BEARINGS WITH THRUST PLATE

Thrust bearings type **AXZ** and **ARZ** have two thrust plates retained by a steel ring giving protection against the entry of dirt and metal particles whilst at the same time assisting retention of the lubricant.

### OPERATION

When the ring of rolling elements begins to rotate, it is automatically centred in relation to the shaft axis. Thus the thrust bearing does not need to be precisely centred by the incorporated plate. Hence it is possible to align the bearing (on the shaft or in the housing) allowing wide tolerances to be used and without surface hardening. This enables costs to be reduced. The same feature applies to centring of the thrust plate.

Thrust bearings with incorporated plate	Separate thrust plates	Thrust bearings with plate and thrust plate incorporated
Needle thrust bearings AX thin series AX thick series	CP thin series CP thick series	Needle thrust bearings AXZ thick series
Roller thrust bearings AR light series		Roller thrust bearings ARZ light series
AR heavy series	CPR heavy series	ARZ heavy series

Needle thrust bearings with a thin plate are of minimal thickness and are particularly economic to use. They should be considered whenever the degree of support and rotational accuracy permits.

# Technical features

## Needle thrust bearings-Roller thrust bearing

### THICKNESS AND AXIAL RUN-OUT TOLERANCES

	Internal Ø D <sub>c1</sub> mm	Thickness tolerance µm	Axial run-out max
Needle thrust bearings (thin)	D <sub>c1</sub> ≤ 60 60 < D <sub>c1</sub> ≤ 90 90 < D <sub>c1</sub> ≤ 120	+ 30/- 40 <sup>1)</sup> + 50/- 60 <sup>2)</sup> + 50/- 60 <sup>2)</sup>	20 <sup>1)</sup> 25 <sup>2)</sup> 30 <sup>2)</sup>
Thrust plates (thin)	D <sub>c1</sub> ≤ 60 60 < D <sub>c1</sub> ≤ 90 90 < D <sub>c1</sub> ≤ 120	+ 30/- 40 <sup>1)</sup> + 50/- 50 <sup>2)</sup> + 50/- 50 <sup>2)</sup>	20 <sup>1)</sup> 25 <sup>2)</sup> 30 <sup>2)</sup>
Needle thrust bearings (thick) Roller thrust bearings	D <sub>c1</sub> ≤ 120 120 < D <sub>c1</sub> ≤ 180 180 < D <sub>c1</sub> ≤ 250	+ 50/- 60 + 50/- 110 + 50/- 160	5 * 7 * 10 *
Thrust plates (thick)	D <sub>c1</sub> ≤ 120 120 < D <sub>c1</sub> ≤ 180 180 < D <sub>c1</sub> ≤ 250	+ 50/- 50 + 50/- 100 + 50/- 150	5 * 7 * 10 *

(1) Under min. load of 150 N

(2) Under min. load of 250 N

### SUPPORTING FACES

For smooth running operation of needle or roller thrust bearings, it is necessary that their supporting faces should be parallel.

For a thrust bearing with intermediate thrust plate, the permissible degree of deviation from true parallelism between the two supporting faces should be no more than 1 min. (or approx. 0.3 per 1000).

For a thrust bearing without intermediate thrust plate, the deviation must be no more than 1 min. 30 sec. (or approx. 0.45 per 1000).

Thin needle thrust bearings and thin thrust plates must be supported on a flat, rigid and continuous face throughout the area of circulation of the needles bounded by dimensions E<sub>b</sub> and E<sub>a</sub>.

Thick needle thrust bearings and thick thrust plates can be supported on a more restricted or discontinuous shoulder, provided that the deflection of the plate under load does not endanger the smooth operation of the thrust bearing or the axial run-out required.

Since roller thrust bearings generally run under considerable loads, their incorporated plate and thrust plate should be supported on a shoulder covering the whole area of circulation of the rollers bounded by dimensions E<sub>b</sub> and E<sub>a</sub>.

Where an application does not involve the use of a thrust plate, the surface forming the second raceway must:

- extend at least across the whole area of circulation of the rolling elements between dimensions E<sub>b</sub> and E<sub>a</sub>;
- possess a suitable surface finish (≤0.5 µm C.L.A.) and sufficient hardness in relation to the load to be supported.

A hardness of 58-64 HRC enables thrust bearings to carry their full load capacity. Lower hardness values reduce the capacities shown in the tables of dimensions (see Technical Section).

### TOLERANCES FOR CENTRING SUPPORTS

*Centring on the shaft:* h10 on dimension D<sub>c1</sub> for thrust bearings or thrust plates.

*Centring in the housing:* H10 on dimension D for thrust bearings and dimension d<sub>1</sub> for thrust plates.

### LOAD RATINGS

#### Minimum axial load

Slippage can occur if the applied axial load is too light and the operating speed of the needle thrust bearings is high – particularly if accompanied by inadequate lubrication. For satisfactory operation, a certain minimum load must be applied to a needle thrust bearing which can be calculated from:

$$F_{a \min} = C_0/2200 \text{ [kN]}$$

Where:

C<sub>0</sub> static load rating [kN]

F<sub>a min</sub> minimum axial load [kN]

### COEFFICIENT OF FRICTION

In general, the coefficient of friction of a thrust bearing (consisting of a needle thrust bearing and thrust plate) is defined as the friction torque, divided by the product of the applied load and the bearing pitch radius. This coefficient of friction is not a constant value, but will vary considerably with load, speed and lubricant.

Generally, the coefficient of friction becomes smaller as the load is increased, and larger as the speed is increased.

It is suggested that a value of 0.008 as a conservative estimate.

### LUBRICATION

Oil is the preferred lubricant for needle thrust bearings and an ample oil flow is absolutely necessary for high speeds or for moderate speeds when the load is relatively high.

When the application must utilize grease lubrication, the needle thrust bearing should be ordered pre-greased.

When the speeds are low and rotation is not continuous, the initial charge of grease may be suitable for the life of the application.

When the speeds are moderate, the designer must provide for frequent re-greasing. Because the needle rollers tend to expel the lubricant radially outward, re-lubrication passages should be directed to the bore of the cage whether oil or grease is used as the lubricant.

### SPECIAL DESIGNS

Needle thrust bearings and thrust plates are made to special dimensions and configurations, as well as from special materials – when quantities permit economical manufacture.



# Mounting arrangements

## Needle thrust bearings with thin thrust plate

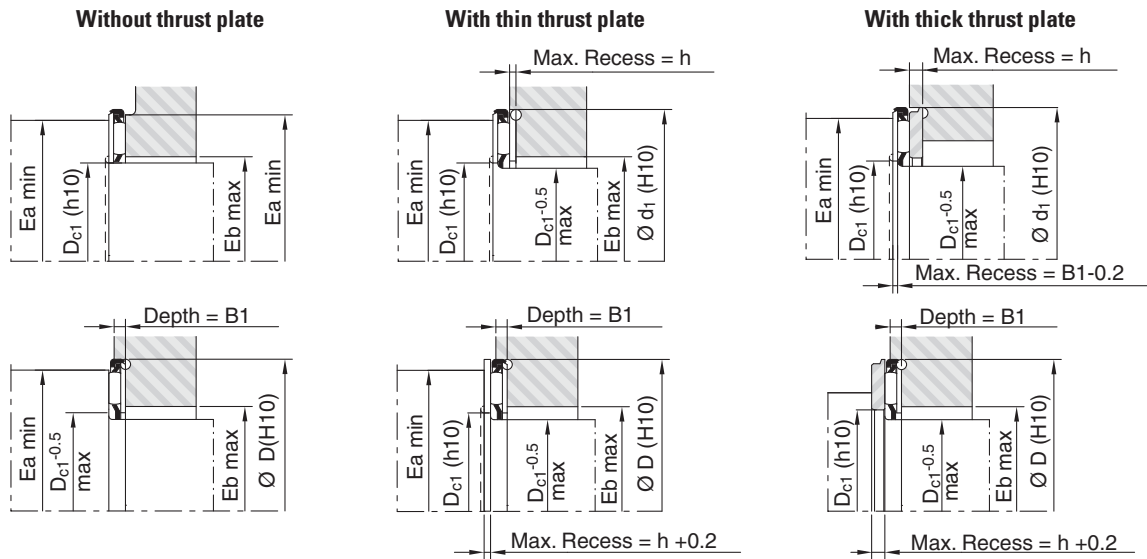

## Needle thrust bearings with thick plate or light series roller thrust bearings

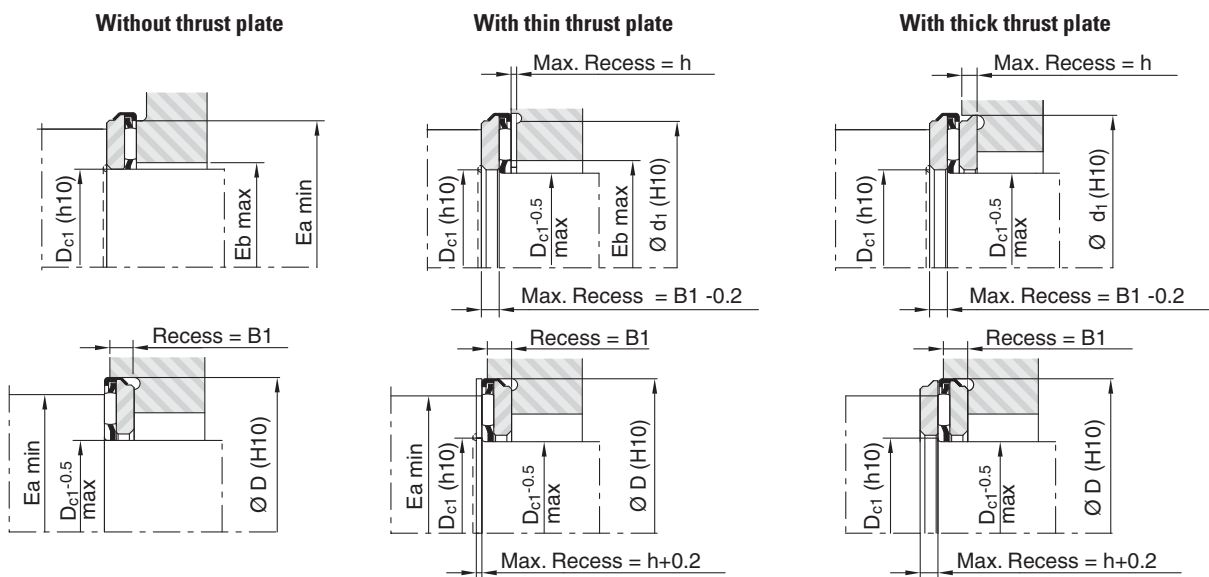

## Mounting for eccentric operation



# Mounting arrangements

## Roller thrust bearings AR heavy series

Without thrust plate

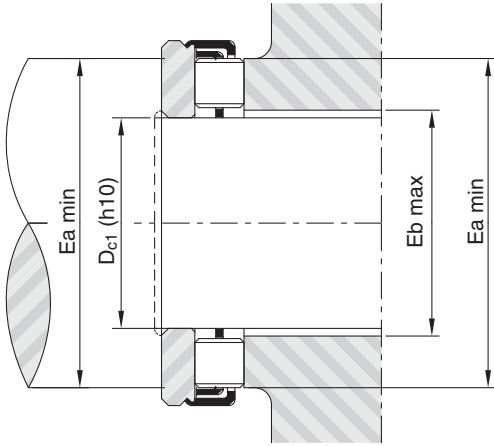

With thick thrust plate

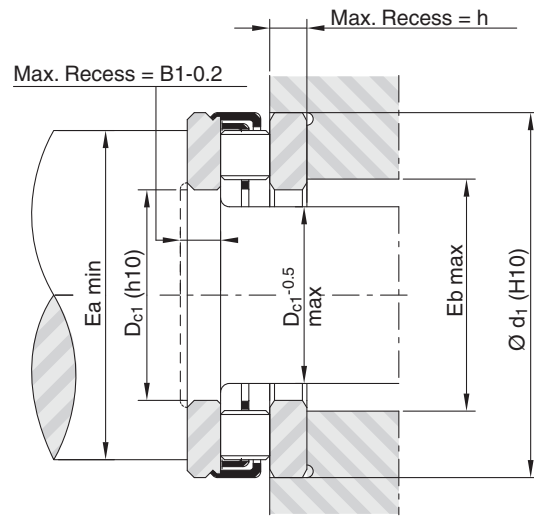

Max. Recess = B1

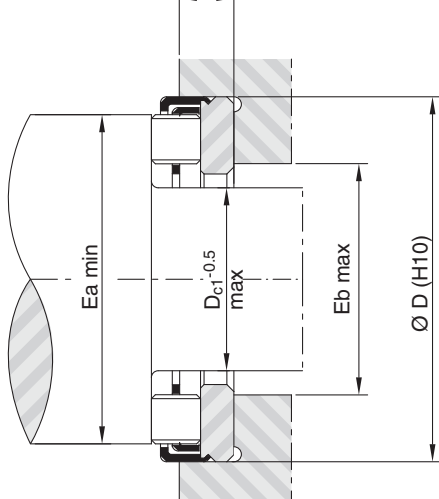

Max. Recess = B1

Max. Recess = h+0.2

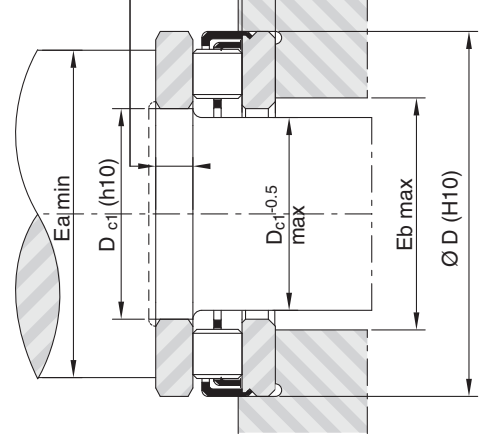

## Needle thrust bearings AXZ or roller thrust bearings ARZ

Mounting for high speed rotation

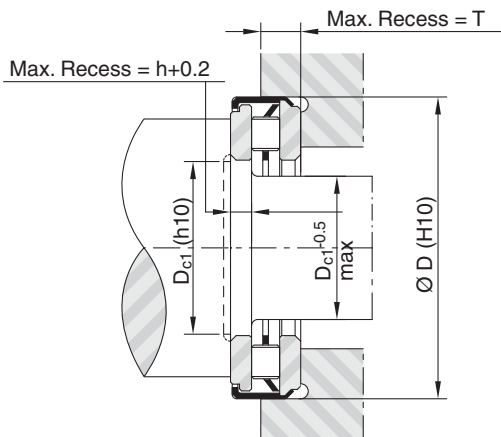

Mounting for slow speed rotation or oscillating motion

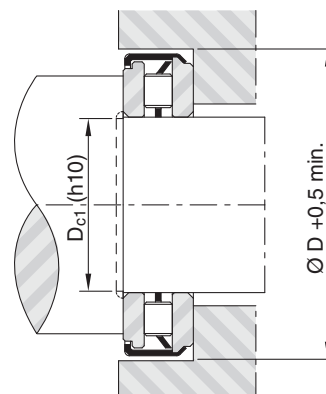

# Needle thrust bearings

## AX thin and thick series

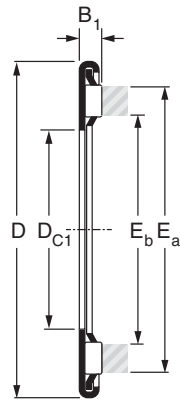

AX thin

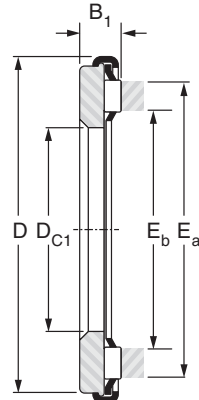

AX thick

Shaft ∅ mm	Designation		Dc1 mm	D mm	B1 mm	Eb mm	Ea mm	Load ratings		Speed rating oil min <sup>-1</sup>	Weight kg
	AX thin series	AX thick series						Dyn. C kN	Stat. Co kN		
5	AX 5 13		5	13	2.3	6.3	10.9	3.00	5.70	25000	0.001
		AX 3.5 5 13	5	13	3.5	6.3	10.9	3.00	5.70	25000	0.002
6	AX 6 14		6	14	2.3	7.3	11.9	3.15	6.35	22000	0.001
		AX 3.5 6 14	6	14	3.5	7.3	11.9	3.15	6.35	22000	0.002
7	AX 7 15		7	15	2.3	8.3	12.9	3.55	7.60	22000	0.002
		AX 3.5 7 15	7	15	3.5	8.3	12.9	3.55	7.60	22000	0.003
8	AX 8 16		8	16	2.3	9.3	13.9	3.70	8.30	22000	0.002
		AX 3.5 8 16	8	16	3.5	9.3	13.9	3.70	8.30	22000	0.003
9	AX 9 17		9	17	2.3	10.3	14.9	4.05	9.50	19000	0.002
		AX 3.5 9 17	9	17	3.5	10.3	14.9	4.05	9.50	19000	0.004
10	AX 10 22		10	22	2.8	12.0	18.6	5.00	10.90	15500	0.004
		AX 4 10 22	10	22	4.0	12.0	18.6	5.00	10.90	15500	0.007
12	AX 12 26		12	26	2.8	15.0	22.6	6.90	17.70	13000	0.006
		AX 4 12 26	12	26	4.0	15.0	22.6	6.90	17.70	13000	0.010
13	AX 13 26		13	26	2.8	15.0	22.6	6.90	17.70	13000	0.006
		AX 4 13 26	13	26	4.0	15.0	22.6	6.90	17.70	13000	0.010
15	AX 15 28		15	28	2.8	17.0	24.6	7.40	20.00	11500	0.007
		AX 4 15 28	15	28	4.0	17.0	24.6	7.40	20.00	11500	0.009
17	AX 17 30		17	30	2.8	19.0	26.6	7.80	22.00	10500	0.008
		AX 4 17 30	17	30	4.0	19.0	26.6	7.80	22.00	10500	0.010
19	AX 19 32		19	32	2.8	21.0	28.6	8.00	23.30	10000	0.009
		AX 4 19 32	19	32	4.0	21.0	28.6	8.00	23.30	10000	0.013
20	AX 20 35		20	35	2.8	22.0	31.6	11.80	39.00	9000	0.010
		AX 5 20 35	20	35	5.0	22.0	31.6	11.80	39.00	9000	0.018
25	AX 25 42		25	42	2.8	27.7	37.4	13.30	49.00	7500	0.012
		AX 5 25 42	25	42	5.0	27.7	37.4	13.30	49.00	7500	0.025
27	AX 27 44		27	44	2.8	30.0	39.6	13.70	52.00	7200	0.012
30	AX 30 47		30	47	2.8	32.7	42.4	14.50	57.00	6500	0.014
		AX 5 30 47	30	47	5.0	32.7	42.4	14.50	57.00	6500	0.029
35	AX 35 52		35	52	2.8	37.2	49.0	18.90	84.00	5500	0.019
		AX 5 35 52	35	52	5.0	37.2	49.0	18.90	84.00	5500	0.035
	AX 35 53		35	53	2.8	37.2	49.0	18.90	84.00	5500	0.019
		AX 5 35 53	35	53	5.0	37.2	49.0	18.90	84.00	5500	0.036

# Thrust plates

## CP thin and thick series

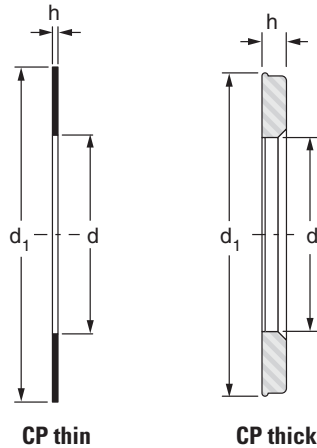

Shaft ∅ mm	Designation		d mm	d <sub>1</sub> mm	h mm	Weight kg	Thrust bearings	
	CP thin series	CP thick series					AX thin series	AX thick serie
5	CP 5 13		5	12.4	0.8	0.001	AX 5 13	
		CP 2 5 13	5	12.4	2.0	0.002		AX 3.5 5 13
6	CP 6 14		6	13.4	0.8	0.001	AX 6 14	
		CP 2 6 14	6	13.4	2.0	0.002		AX 3.5 6 14
7	CP 7 15		7	14.4	0.8	0.001	AX 7 15	
		CP 2 7 15	7	14.4	2.0	0.002		AX 3.5 7 15
8	CP 8 16		8	15.4	0.8	0.001	AX 8 16	
		CP 2 8 16	8	15.4	2.0	0.002		AX 3.5 8 16
9	CP 9 17		9	16.4	0.8	0.001	AX 9 17	
		CP 2 9 17	9	16.4	2.0	0.002		AX 3.5 9 17
10	CP 10 22		10	21.5	0.8	0.002	AX 10 22	
		CP 2 10 22	10	21.5	2.0	0.002		AX 4 10 22
12	CP 12 26		12	25.5	0.8	0.003	AX 12 26	
		CP 2 12 26	12	25.5	2.0	0.006		AX 4 12 26
13	CP 13 26		13	25.5	0.8	0.002	AX 13 26	
		CP 2 13 26	13	25.5	2.0	0.006		AX 4 13 26
15	CP 15 28		15	27.5	0.8	0.003	AX 15 28	
		CP 2 15 28	15	27.5	2.0	0.006		AX 4 15 28
17	CP 17 30		17	29.5	0.8	0.003	AX 17 30	
		CP 2 17 30	17	29.5	2.0	0.007		AX 4 17 30
19	CP 19 32		19	31.5	0.8	0.004	AX 19 32	
		CP 2 19 32	19	31.5	2.0	0.009		AX 4 19 32
20	CP 20 35		20	34.5	0.8	0.004	AX 20 35	
		CP 3 20 35	20	34.5	3.0	0.013		AX 5 20 35
25	CP 25 42		25	41.5	0.8	0.005	AX 25 42	
		CP 3 25 42	25	41.5	3.0	0.019		AX 5 25 42
27	CP 27 44		27	43.7	0.8	0.006	AX 27 44	
30	CP 30 47		30	46.5	0.8	0.006	AX 30 47	
		CP 3 30 47	30	46.5	3.0	0.022		AX 5 30 47
35	CP 35 52		35	51.5	0.8	0.007	AX 35 52	
		CP 3 35 52	35	51.5	3.0	0.026		AX 5 35 52
	CP 35 53		35	52.5	0.8	0.007	AX 35 53	
		CP 3 35 53	35	52.5	3.0	0.027		AX 5 35 53

# Needle thrust bearings

## AX thin and thick series

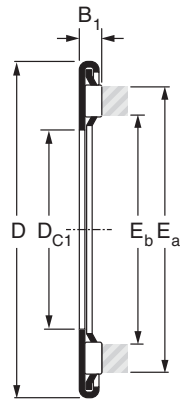

AX thin

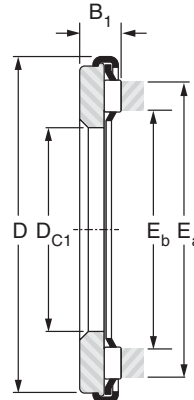

AX thick

Shaft ∅ mm	Designation		Dc1 mm	D mm	B1 mm	Eb mm	Ea mm	Load ratings		Speed rating oil min <sup>-1</sup>	Weight kg
	AX thin series	AX thick series						Dyn. C kN	Stat. Co kN		
40	AX 40 60		40	60	2.8	43.0	54.9	20.40	96.00	5000	0.024
		AX 5 40 60	40	60	5.0	43.0	54.9	20.40	96.00	5000	0.046
45	AX 45 65		45	65	2.8	48.0	59.9	21.80	109	4500	0.025
		AX 5 45 65	45	65	5.0	48.0	59.9	21.80	109	4500	0.050
50	AX 50 70		50	70	2.8	53.3	65.7	22.50	118	4000	0.026
		AX 5 50 70	50	70	5.0	53.3	65.7	22.50	118	4000	0.055
55	AX 55 78		55	78	2.8	58.4	72.5	28.50	164	3800	0.034
		AX 6 55 78	55	78	6.0	58.4	72.5	28.50	164	3800	0.089
60	AX 60 85		60	85	2.8	63.5	79.2	31.50	193	3500	0.040
		AX 6 60 85	60	85	6.0	63.5	79.2	31.50	193	3500	0.106
65	AX 3.5 65 90		65	90	3.5	68.5	84.2	33.50	210	3200	0.059
		AX 6 65 90	65	90	6.0	68.5	84.2	33.50	210	3200	0.114
70	AX 3.5 70 95		70	95	3.5	73.5	89.2	34.50	223	3000	0.061
		AX 6 70 95	70	95	6.0	73.5	89.2	34.50	223	3000	0.120
75	AX 3.5 75 100		75	100	3.5	78.5	94.2	36.00	240	2900	0.065
		AX 6 75 100	75	100	6.0	78.5	94.2	36.00	240	2900	0.127
80	AX 3.5 80 105		80	105	3.5	83.5	99.2	36.50	253	2700	0.069
		AX 6 80 105	80	105	6.0	83.5	99.2	36.50	253	2700	0.134
85	AX 3.5 85 110		85	110	3.5	88.5	104.2	38.00	270	2600	0.078
		AX 6 85 110	85	110	6.0	88.5	104.2	38.00	270	2600	0.142
90	AX 4.5 90 120		90	120	4.5	94.2	112.9	59.00	360	2400	0.117
		AX 8 90 120	90	120	8.0	94.2	112.9	59.00	360	2400	0.238
100	AX 4.5 100 135		100	135	4.5	104.2	127.3	73.00	490	2100	0.155
		AX 9 100 135	100	135	9.0	104.2	127.3	73.00	490	2100	0.364
110	AX 4.5 110 145		110	145	4.5	114.2	137.3	77.00	550	2000	0.168
		AX 9 110 145	110	145	9.0	114.2	137.3	77.00	550	2000	0.393
120	AX 4.5 120 155		120	155	4.5	124.2	147.3	80.00	590	1800	0.182
		AX 9 120 155	120	155	9.0	124.2	147.3	80.00	590	1800	0.424



# Thrust plates

## CP thin and thick series

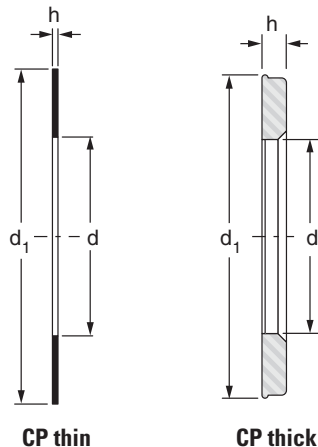

Shaft ∅ mm	Designation		d mm	d <sub>1</sub> mm	h mm	Weight kg	Thrust bearings	
	CP thin series	CP thick series					AX thin series	AX thick serie
40	CP 40 60		40	59.5	0.8	0.009	AX 40 60	
		CP 3 40 60	40	59.5	3.0	0.034		AX 5 40 60
45	CP 45 65		45	64.4	0.8	0.010	AX 45 65	
		CP 3 45 65	45	64.4	3.0	0.037		AX 5 45 65
50	CP 50 70		50	69.4	0.8	0.011	AX 50 70	
		CP 3 50 70	50	69.4	3.0	0.040		AX 5 50 70
55	CP 55 78		55	77.4	0.8	0.014	AX 55 78	
		CP 4 55 78	55	77.4	4.0	0.069		AX 6 55 78
60	CP 60 85		60	84.3	0.8	0.017	AX 60 85	
		CP 4 60 85	60	84.3	4.0	0.083		AX 6 60 85
65	CP 1.5 65 90		65	89.3	1.5	0.033	AX 3.5 65 90	
		CP 4 65 90	65	89.3	4.0	0.088		AX 6 65 90
70	CP 1.5 70 95		70	94.3	1.5	0.034	AX 3.5 70 95	
		CP 4 70 95	70	94.3	4.0	0.093		AX 6 70 95
75	CP 1.5 75 100		75	99.3	1.5	0.037	AX 3.5 75 100	
		CP 4 75 100	75	99.3	4.0	0.099		AX 6 75 100
80	CP 1.5 80 105		80	104.3	1.5	0.039	AX 3.5 80 105	
		CP 4 80 105	80	104.3	4.0	0.104		AX 6 80 105
85	CP 1.5 85 110		85	109.3	1.5	0.047	AX 3.5 85 110	
		CP 4 85 110	85	109.3	4.0	0.111		AX 6 85 110
90	CP 1.5 90 120		90	118.8	1.5	0.052	AX 4.5 90 120	
		CP 5 90 120	90	118.8	5.0	0.173		AX 8 90 120
100	CP 1.5 100 135		100	133.8	1.5	0.068	AX 4.5 100 135	
		CP 6 100 135	100	133.8	6.0	0.277		AX 9 100 135
110	CP 1.5 110 145		110	143.8	1.5	0.075	AX 4.5 110 145	
		CP 6 110 145	110	143.8	6.0	0.300		AX 9 110 145
120	CP 1.5 120 155		120	153.8	1.5	0.081	AX 4.5 120 155	
		CP 6 120 155	120	153.8	6.0	0.323		AX 9 120 155

# Needle thrust bearings

## AX thick series

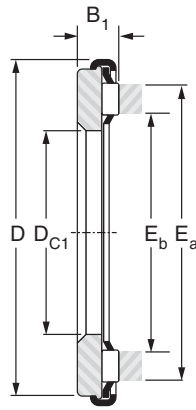

AX thick

Shaft ∅ mm	Designation	D <sub>C1</sub> mm	D mm	B <sub>1</sub> mm	E <sub>b</sub> mm	E <sub>a</sub> mm	Load ratings		Speed rating oil min <sup>-1</sup>	Weight kg
	AX thick series						Dyn. C kN	Stat. Co kN		
130	AX 11 130 170	130	170	11	135	161	106	710	1700	0.660
140	AX 11 140 180	140	180	11	145	171	111	770	1600	0.670
150	AX 11 150 190	150	190	11	155	181	115	830	1500	0.710
160	AX 11 160 200	160	200	11	165	191	118	870	1400	0.760
170	AX 12 170 215	170	215	12	175	207	165	1160	1300	1.000
180	AX 12 180 225	180	225	12	185	217	173	1250	1200	1.050
190	AX 14 190 240	190	240	14	196	232	230	1650	1200	1.400
200	AX 14 200 250	200	250	14	206	242	239	1730	1100	1.500
220	AX 14 220 270	220	270	14	226	262	248	1850	1000	1.600
240	AX 15 240 300	240	300	15	246	286	280	2240	900	2.300

# Thrust plates

## CP thick series

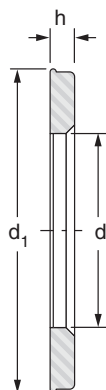

CP thick

Shaft ∅ mm	Designation	d mm	d <sub>1</sub> mm	h mm	Weight kg	Thrust bearings
	CP thick series					AX thick serie
130	CP 7 130 170	130	168.7	7.0	0.480	AX 11 130 170
140	CP 7 140 180	140	178.7	7.0	0.500	AX 11 140 180
150	CP 7 150 190	150	188.7	7.0	0.530	AX 11 150 190
160	CP 7 160 200	160	198.7	7.0	0.560	AX 11 160 200
170	CP 7 170 215	170	213.5	7.0	0.700	AX 12 170 215
180	CP 7 180 225	180	223.5	7.0	0.735	AX 12 180 225
190	CP 8 190 240	190	238.3	8.0	0.950	AX 14 190 240
200	CP 8 200 250	200	248.3	8.0	1.000	AX 14 200 250
220	CP 8 220 270	220	268.3	8.0	1.100	AX 14 220 270
240	CP 9 240 300	240	298.5	9.0	1.600	AX 15 240 300

# Roller thrust bearings

## AR light and heavy series

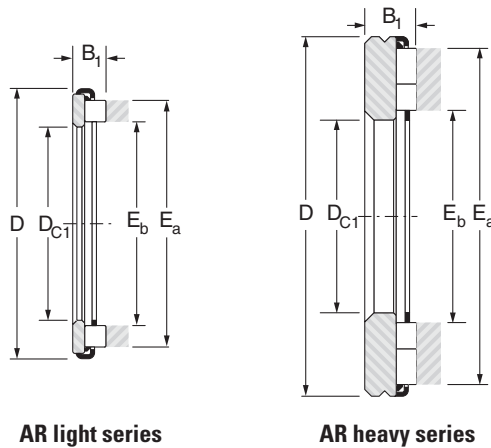

AR light series

AR heavy series

Shaft ∅ mm	Designation		D <sub>C1</sub> mm	D mm	B <sub>1</sub> mm	E <sub>b</sub> mm	E <sub>a</sub> mm	Load ratings		Speed rating oil min <sup>-1</sup>	Weight kg
	AR light series	AR heavy series						Dyn. C kN	Stat. Co kN		
10	AR 4.5 10 22		10	22	4.5	12.2	18.5	8.2	17.9	15500	0.007
12	AR 5 12 26		12	26	5	14.8	22.9	12.7	29.5	13000	0.011
15	AR 5 15 28		15	28	5	16.8	24.9	14.0	34.0	11500	0.011
17	AR 5 17 30		17	30	5	18.8	26.9	15.0	39.0	10500	0.013
20	AR 7 20 35		20	35	7	22.0	31.6	22.0	54.0	9000	0.022
25	AR 7 25 42		25	42	7	27.7	37.3	25.5	70.0	7500	0.031
		AR 7 25 52	25	52	7	29.0	47.0	32.5	122.0	6500	0.070
30	AR 7 30 47		30	47	7	32.7	42.3	26.5	77.0	6500	0.036
		AR 9 30 60	30	60	9	33.5	53.5	46.0	162.0	5600	0.113
35	AR 8 35 53.4		35	53.4	8	37.8	47.8	33.8	94.0	5500	0.052
		AR 9 35 68	35	68	9	39.0	60.6	51.0	194.0	4900	0.144
40	AR 9 40 60.4		40	60.4	9	42.8	54.8	46.0	129.0	5000	0.070
		AR 11 40 78	40	78	11	44.0	70.0	71.0	265.0	4200	0.225
45	AR 9 45 65.4		45	65.4	9	47.8	59.8	49.0	143.0	4500	0.077
		AR 14 45 85	45	85	14	49.0	77.0	92.0	340.0	3800	0.350
50	AR 9 50 70.4		50	70.4	9	52.8	64.8	51.0	157.0	4000	0.082
		AR 14 50 95	50	95	14	54.0	86.0	108.0	430.0	3400	0.448
55	AR 10 55 78.4		55	78.4	10	58.5	72.5	61.0	203.0	3800	0.125
		AR 14 55 105	55	105	14	60.2	96.2	125.0	530.0	3100	0.537
60	AR 10 60 85.4		60	85.4	10	63.5	79.5	71.0	255.0	3500	0.150
		AR 14 60 110	60	110	14	65.2	101.2	130.0	580.0	2900	0.572
65	AR 10 65 90.4		65	90.4	10	68.5	84.5	74.0	275.0	3200	0.160
		AR 14 65 115	65	115	14	70.2	106.2	135.0	620.0	2800	0.610
70	AR 10 70 95.4		70	95.4	10	73.5	89.5	77.0	295.0	3000	0.170
		AR 16 70 125	70	125	16	76.0	116.0	174.0	710.0	2600	0.775

# Thrust plates

## CP thin and thick series, CPR heavy series

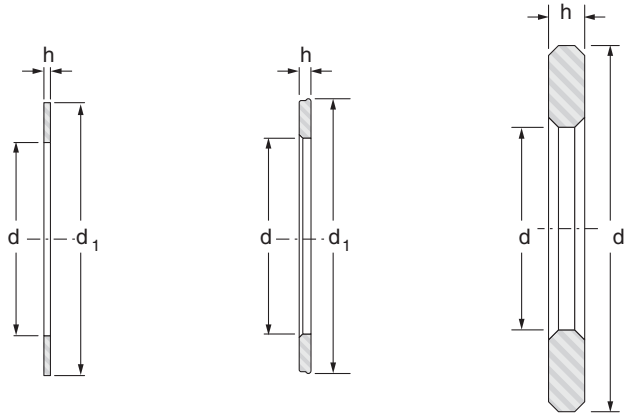

CP thin series

CP thick series

CPR heavy series

Shaft ∅ mm	d mm	d <sub>1</sub> mm	Designation	h mm	Weight kg	Designation	h mm	Weight kg	Designation	h mm	Weight kg
			CP Thin series			CP Thick series			CPR Heavy series		
10	10	21.5	CP 10 22	0.8	0.002	CP 2 10 22	2	0.004			
12	12	25.5	CP 12 26	0.8	0.003	CP 2 12 26	2	0.006			
15	15	27.5	CP 15 28	0.8	0.003	CP 2 15 28	2	0.006			
17	17	29.5	CP 17 30	0.8	0.003	CP 2 17 30	2	0.007			
20	20	34.5	CP 20 35	0.8	0.004	CP 3 20 35	3	0.013			
25	25	41.5	CP 25 42	0.8	0.005	CP 3 25 42	3	0.019			
	25	52							CPR 4 25 52	4	0.052
30	30	46.5	CP 30 47	0.8	0.006	CP 3 30 47	3	0.022			
	30	60							CPR 5 30 60	5	0.083
35	35	51.5	CP 35 52	0.8	0.007	CP 3 35 52	3	0.026			
	35	68							CPR 5 35 68	5	0.102
40	40	59.5	CP 40 60	0.8	0.009	CP 3 40 60	3	0.034			
	40	78							CPR 6 40 78	6	0.162
45	45	64.4	CP 45 65	0.8	0.010	CP 3 45 65	3	0.037			
	45	85							CPR 8 45 85	8	0.245
50	50	69.4	CP 50 70	0.8	0.011	CP 3 50 70	3	0.040			
	50	95							CPR 8 50 95	8	0.308
55	55	77.4	CP 55 78	0.8	0.014	CP 4 55 78	4	0.069			
	55	105							CPR 8 55 105	8	0.380
60	60	84.3	CP 60 85	0.8	0.017	CP 4 60 85	4	0.083			
	60	110							CPR 8 60 110	8	0.405
65	65	89.3	CP 1.5 65 90	1.5	0.033	CP 4 65 90	4	0.088			
	65	115							CPR 8 65 115	8	0.430
70	70	94.3	CP 1.5 70 95	1.5	0.034	CP 4 70 95	4	0.093			
	70	125							CPR 8 70 125	8	0.510

# Roller thrust bearings

## AR light and heavy series

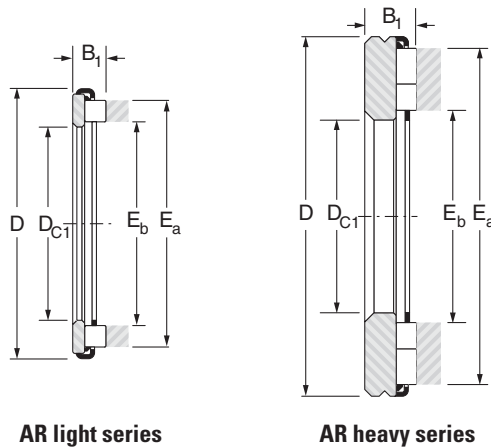

Shaft ∅ mm	Designation		D <sub>C1</sub> mm	D mm	B <sub>1</sub> mm	E <sub>b</sub> mm	E <sub>a</sub> mm	Load ratings		Speed rating oil min <sup>-1</sup>	Weight kg
	AR light series	AR heavy series						Dyn. C kN	Stat. Co kN		
75	AR 10 75 100.4		75	100	10	78.5	94.5	80.0	313.0	2800	0.180
		AR 16 75 135	75	135	16	82.0	126.0	198.0	860.0	2400	0.893
80	AR 10 80 105.4		80	105	10	83.5	99.5	82.0	330.0	2700	0.190
		AR 16 80 140	80	140	16	87.0	131.0	208.0	940.0	2300	0.960
85		AR 18 85 150	85	150	18	92.0	138.0	230.0	1010.0	2100	1.256
90		AR 18 90 155	90	155	18	97.0	143.0	245.0	1090.0	2000	1.330
100		AR 20 100 170	100	170	20	109.0	157.0	280.0	1250.0	1800	1.740
110		AR 24 110 190	110	190	24	118.0	178.0	365.0	1600.0	1700	2.500
120		AR 24 120 210	120	210	24	127.0	199.0	470.0	2300.0	1500	3.200
130		AR 24 130 225	130	225	24	138.0	214.0	510.0	2640.0	1400	3.600
140		AR 28 140 240	140	240	28	149.0	229.0	600.0	2980.0	1300	4.800

# Thrust plates

## CP thin and thick series, CPR heavy series

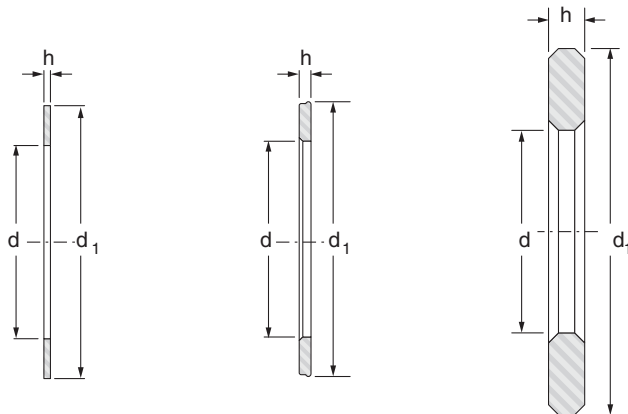

CP thin series

CP thick series

CPR heavy series

Shaft ∅ mm	d mm	d <sub>1</sub> mm	CP Thin series			CP Thick series			CPR Heavy series		
			Designation CP Thin series	h mm	Weight kg	Designation CP Thick series	h mm	Weight kg	Designation CPR Heavy series	h mm	Weight kg
75	75	99.3	CP 1.5 75 100	1.5	0.037	CP 4 75 100	4	0.099			
	75	135							CPR 8 75 135	8	0.595
80	80	104.3	CP 1.5 80 105	1.5	0.039	CP 4 80 105	4	0.104			
	80	140							CPR 8 80 140	8	0.630
85	85	150							CPR 9 85 150	9	0.815
90	90	155							CPR 9 90 155	9	0.840
100	100	170							CPR 10 100 170	10	1.13
110	110	190							CPR 12 110 190	12	1.70
120	120	210							CPR 12 120 210	12	2.10
130	130	225							CPR 12 130 225	12	2.40
140	140	240							CPR 14 140 240	14	3.20

# Roller and needle thrust bearings with thrust plate - AXZ and ARZ light and heavy series

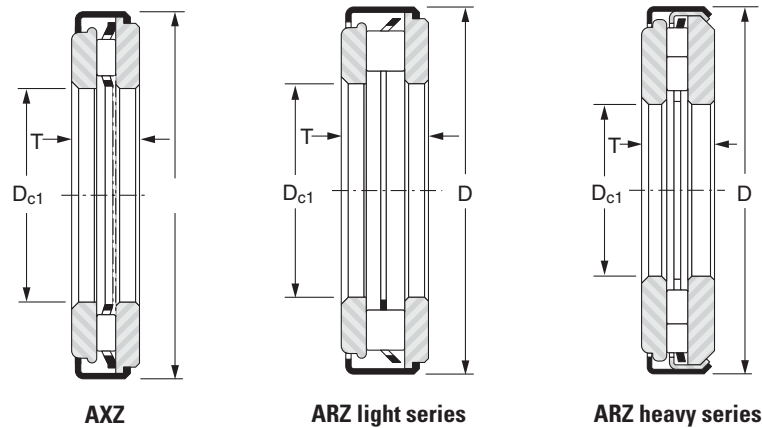

Shaft ∅ mm	Designation			d mm	D mm	T mm	Load ratings		Speed rating oil min <sup>-1</sup>	Weight kg
	AXZ	ARZ light series	ARZ heavy series				Dyn. C kN	Stat. Co kN		
5	AXZ 5.5 5 13			5	13	5.5	3.00	5.70	25000	0.004
6	AXZ 5.5 6 14			6	14	5.5	3.15	6.35	22000	0.004
7	AXZ 5.5 7 15			7	15	5.5	3.55	7.60	22000	0.005
8	AXZ 5.5 8 16			8	16	5.5	3.70	8.30	22000	0.005
9	AXZ 5.5 9 17			9	17	5.5	4.05	9.50	19000	0.005
10	AXZ 6 10 22.4			10	22.4	6	5.00	10.9	15500	0.011
		ARZ 6.5 10 22.4		10	22.4	6.5	8.20	17.9	15500	0.012
12	AXZ 6 12 26.4			12	26.4	6	6.90	17.7	13000	0.017
		ARZ 7 12 26.4		12	26.4	7	12.7	29.5	13000	0.017
15	AXZ 6 15 28.4			15	28.4	6	7.40	20.0	11500	0.016
		ARZ 7 15 28.4		15	28.4	7	14.0	34.0	11500	0.019
17	AXZ 6 17 30.4			17	30.4	6	7.80	22.0	10500	0.018
		ARZ 7 17 30.4		17	30.4	7	15.0	39.0	10500	0.022
20	AXZ 8 20 35.4			20	35.4	8	11.80	39.0	9000	0.033
		ARZ 10 20 35.4		20	35.4	10	22.0	54.0	9000	0.038
25	AXZ 8 25 43			25	43	8	13.30	49.0	7500	0.047
		ARZ 10 25 43		25	43	10	25.5	70.0	7500	0.057
			ARZ 11 25 53	25	53	11	32.5	122	6500	0.122
30	AXZ 8 30 48			30	48	8	14.50	57.0	6500	0.054
		ARZ 10 30 48		30	48	10	26.5	77.0	6500	0.065
			ARZ 14 30 61	30	61	14	46.0	162	5600	0.196
35	AXZ 8 35 54			35	54	8	18.90	84.0	5500	0.066
		ARZ 11 35 54		35	54	11	33.8	94.0	5500	0.087
			ARZ 14 35 69	35	69	14	51.0	194.0	4900	0.246



# Roller and needle thrust bearings with thrust plate - AXZ and ARZ light and heavy series

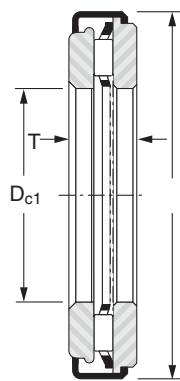

AXZ

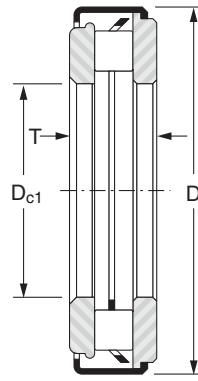

ARZ light series

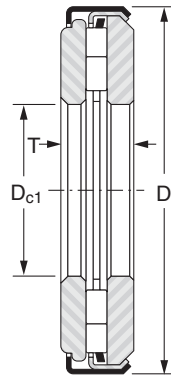

ARZ heavy series

Shaft ∅ mm	Designation			d mm	D mm	T mm	Load ratings		Speed rating oil min <sup>-1</sup>	Weight kg
	AXZ	ARZ light series	ARZ heavy series				Dyn. C kN	Stat. Co kN		
40	AXZ 8 40 61			40	61	8	20.40	96.0	5000	0.084
		ARZ 12 40 61		40	61	12	46.0	129	5000	0.114
			ARZ 17 40 79	40	79	17	71.0	265	4200	0.387
45	AXZ 8 45 66			45	66	8	21.80	109	4500	0.092
		ARZ 12 45 66		45	66	12	49.0	143	4500	0.126
			ARZ 22 45 86	45	86	22	92.0	340	3800	0.595
50	AXZ 8 50 71			50	71	8	22.50	118	4000	0.100
		ARZ 12 50 71		50	71	12	51.0	157	4000	0.137
			ARZ 22 50 96	50	96	22	108.0	430	3400	0.756
55			ARZ 22 55 106	55	106	22	125.0	530	3100	0.917
60	AXZ 10 60 86			60	86	10	31.50	193	3500	0.194
		ARZ 14 60 86		60	86	14	71.0	255	3500	0.246
			ARZ 22 60 111	60	111	22	130.0	580	2900	0.977
65			ARZ 22 65 116	65	116	22	135.0	620	2800	1.040
70	AXZ 10 70 96			70	96	10	34.50	223	3000	0.220
		ARZ 14 70 96		70	96	14	77.0	295	3000	0.279
80	AXZ 10 80 106			80	106	10	36.50	253	2700	0.256
		ARZ 14 80 106		80	106	14	82.0	330	2700	0.312